

High quality components ...



...in a sturdy stainless steel cabinet

Main characteristics

- Capacity: 150 kg/24 h flake ice chipped type
- Production of flake ice chipped type with $-0,5\text{ }^{\circ}\text{C}$ from drinking water or demineralized water - Standard- or Microlce
- Designed for continuous operation - 24 hours - 7 days a week
- Hygienic Design: Closed watersystem - protected against contamination by external influences
- Environmental friendly technology - Natural refrigerant Propane - R290
No moving parts in the refrigeration circuit of the evaporator - no refrigerant leakage



StandardIce

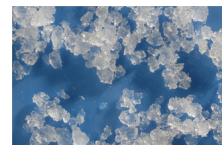

Microlce

Dimensions and connections

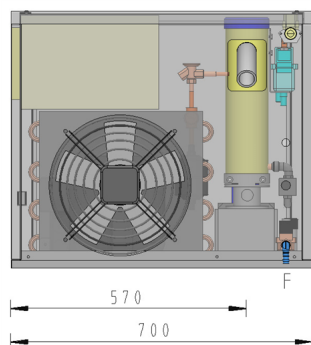
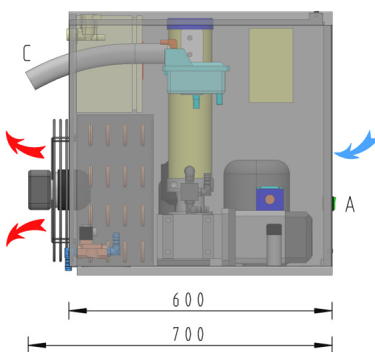

- A operating switch
- C ice discharge
- D electr. connection
- E water supply
- F water drain

provided by customer
water filter
stop cock
electr. protection
waste water connection
(contactless)

Technical Data

	ZBE 150
150 kg/24 h nominal capacity at	20 °C air temperature and 15 °C water temperature
dimensions (L x W x H)	60 cm x 70 cm x 60 cm
weight	80 kg
cabinet	stainless steel 1.4301
electricity	
power consumption	0,8 kW
full-load electricity	3,6 A
degree of protection	IP 54
provided by customer	
electric supply	1/N/PE ~ 230V 50 Hz
fuse, slow-blow	16 A
cable cross section, Cu	1,5 mm ²
water	
water supply	3/4 " male thread
water drain	14 mm hose nozzle
provided by customer	
pressure	1 - 5 bar
quality	drinking water
pH-value	7,2 - 9,5 pH
hardness	6 - 14 °dH
temperature	100 - 250 mg CaCO ₃ /l 5 °C - 30 °C
ambient temperature	5 °C - 42 °C
condenser	air cooled
air flow	440 m ³ /h
heat emission	2 kW
refrigerant R290	0,112 kg
compressor	fully hermetic
refrigerating capacity	0,69 kW
evaporation temperature	-14 °C
condensation temperature	36 °C
noise level	50 dBA (3 m)

Subject to technical modifications. In case of deviations please contact us.

Scope of supply

The ZIEGRA ice machine will be delivered according to CE standards and ready for connection to water and electricity.

ZIEGRA quality and reliability

- High / Low pressure control
- Water level monitoring
- Motor protection -
for the compressor

Included accessories

- Flexible ice discharging hose
- Switch-off by thermostat when the ice bin
or recipient is full.
- Connecting cable 5 m
- Flexible hose water supply 2 m
- Water drain hose 2 m
- PE ice shovel